



MAINTENANCE AND SAFETY REQUIREMENTS OF EX-D EQUIPMENT

Abstract

In the generation of the new technology segment, new explosionproof (Ex) equipment are being installed to make systems suitable for use in hazardous areas of mines. Generally, 80-90% equipment having flameproof (Exd) and intrinsic safety (Exi) methodology of protection are used in the mines for safe operation. The maintenance and safety are two vital parameters to improve the system efficiency of installation in the mines. These parameters are also responsible for the productivity of the mines. The minimum breakdown and maximum safety are the prime concerns of the mines to increase the production. Many observations and basic knowledge are necessary of safety parameters of Ex protections while doing maintenance because micro joules energy is sufficient to ignite the hazardous areas of mines. Trained andskilled personals having good knowledge of Ex protections are required to maintain the limitations of ignition energy sources of Ex equipment to prevent explosion in the mines. A regular and organized scheme of inspection and maintenance may ensure continued, satisfactory and safe operation of Ex electrical equipment.

1. Introduction

The general state of the whole equipment needs to be periodically checked, by applying the specified periodic inspections, and if necessary, measures to their remedy need to be taken. The current actions undertaken in order to maintain the state of full operation of the installed equipments is called maintenance. The maintenance of the integrity of the type of protection foreseen for the equipment has to be especially considered. Spare parts must be as per the documentation for the safety protection and assurance [1]. Coal mining is the important sector of any country's economy. In the coal mines a flammable atmosphere may be present in the form of gas, vapor and dust and it is classified as group I. It is a statutory requirement that some safeguards are required to apply in electrical and electronic equipment to prevent ignition source from these equipment. It is possible only when proper, timely and cost effective installation and maintenance is done. If proper maintenance is not done timely then there are lots of chances of improper function or creation of arc/spark from the Ex equipment which can cause for explosion in the hazardous area. Maintenance of Ex equipment should always be done in the safe area only except some equipment, if live maintenance is carried out, it should be specified in certificate or procedure declared by the manufacturer. The continuous education and skilled training about type of protections and its importance are required to the concerned manpower to minimize the risk of explosion from Ex equipment. Generally, the certification of Ex equipment does not include the maintenance documents. So the Ex equipment manufacturer must decide that what is adequate maintenance schedule and try to anticipate the possible use of Ex equipment safely. This is the responsibility of manufacturer/ supplier to supply all documents alongwith the Ex equipment so user can use when it is needed. The history of each equipment should be recorded, if any maintenance is carried out.

Intrinsic safety is a technique in which energy is limited within the circuit of the apparatus. Intrinsically safe apparatus does not require any special form of enclosure but certain safeguards are required as per IS/IEC 60079-11 [2]. If it is associated apparatus then additional measures are required. An electrical apparatus and its associated circuits have to be



designed in a manner that it will prevent the generation of arcs, sparks, or thermal effects that could not become a ignition source for explosion during both normal and fault conditions of the circuit. The labels plate, name plate and warning plate should be made of stainless steel or brass but not be manufactured from light metal alloy. Labels shall be permanently fixed and indelibly marked. Engraved or etched and filled stainless steel labels can be preferred. The relevant information like product name, specification detail, marking, standard specification, certificate number and approval number at least shall be permanently available on the plate and affixed on Ex equipment in an easily seen position and the detail of Ex equipment should be recorded for reference to procure new one in future.

Exd and Exi are the most commonly used equipment protection methods in coal mines. In Exd protection method, the energy source is permitted to come in contact with the explosive air-gas mixture. Consequently, the explosion is allowed to take place, but it must remain confined in an enclosure built to resist the excess pressure created by an internal explosion, thus impeding the propagation to the surrounding explosive atmosphere. The design of an enclosure should be such that the flame should not be transmitted to the outer atmosphere. One advantage of intrinsic safety over flame proof enclosure is that the live maintenance may be carried out if needed in hazardous area. The maintenance people should always ensure human and equipment safety. It should also be ensured that installations are maintained in a satisfactory condition for continued safe use within a hazardous area of mines. The equipment should be inspected periodically as per schedule. Repair and maintenance should only be carried out by 'skilled personnel' and such personnel should be adequately trained for Exd and Ex i protections of methodology.

If the flameproof enclosures are reassembled, all the joints need to be thoroughly cleaned and lubricated easily with a sort of Vaseline for the prevention of corrosion. In order to clean the flanges of flameproof joints, non-metallic and noncorrosive cleaning products should be used. In the flange joint the gaps are too small. A small gap can be closed by dirt which may result of burst due to non release of pressure through gap.

There is no risk of a significant electric shock to a technician doing live maintenance on an intrinsically safe circuit but sometimes it can happen. The design of intrinsically safe apparatus and systems ensures that the short circuit and open circuit of field wiring cannot produce sufficient ignition energy to explode the explosive atmospheres. The concept of live maintenance uses this feature but does not extend to carrying out detailed repairs; like, repairing printed circuit boards, repairing of components within the hazardous areas. The installation of IS devices and associated equipment must conform to IS/IEC 60079-14 requirements [3]. The cable trays, ducts and conduits should not be common for Exd and Exi equipment.



2. Maintenance of Flameproof Equipment

There is several type of Exd equipment are being used in the underground coal mines. These are mainly motor, light fixture, junction box (JB), control panel (CP), plug and socket, cable gland, stopping/closing device, etc. The opening and checking of Exd equipment in energised condition are not permitted in the hazardous area but if required, it should be done in the safe area only. The maintenance or checking of any sort shall not be ever done on live parts of flameproof equipment in hazardous area. A written permission is required from the concerned person for any repair / maintenance job in hazardous areas. The precaution includes replacement parts must be genuine and identical only and it should be certified and approved for use in hazardous area. Any alteration is done without authorization invalidates the Type Test Certificate of Ex equipment and end user is responsible for any explosion if it occurs after alteration.

Any build-up of dust on the luminaire should be removed, this can cause overheating as well as acting as a corrosive agent. It should be ensured that bolts are not over-tightened as this can distort flamepaths, cause excessive stress on lampglasses or distort weather proofing gaskets, if fitted, allowing the ingress of liquids and dusts. It is required to check the luminaire that is installed in accordance with the requirements of the installation and temperature class. The non-setting silicone grease can be applied on the threaded joint. The cement/epoxy compound used around the glass assemblies both inside and outside should be checked. If the cement is eroded, softened or damaged in any way, advice should be sought from the manufacturer /supplier regarding repair. If deterioration of the cement/epoxy compound has occurred, a complete new glass assembly should be replaced. If the flamepath needs cleaning, this should be done with a non-metallic scraper and/or a suitable non-corrosive cleaning fluid. It should be ensured that there are no missing bolts in the flameproof enclosure. This is particularly important on flameproof enclosure because a missing bolt will invalidate the certification and increase risk of explosion.

2.1. Flameproof Motor

It is required to check the flameproof feature (like flamepath, gap etc.) which depends on gross volume of enclosure of motor. The gap should be maintained as specified in the test report after reassembling. The locations of flamepath and gap/diametrical clearance in flameproof motor are shown in Figure 1. The flamepath between shaft of rotating machine and gland is very important and it may be arranged with motor driving end (DE) shield and non driving end (NDE) shield in different ways. The sleeve bearing should not be used in the gas group IIC for motor because it is not allowed due to non-uniform radial clearance [4]. The rolling bearing should be replaced with identical one and check permissible radial clearance between bearing and gland, if any. The proper clearance should be maintained between the internal fan and its hood. Sealing should be done properly and safely in the sealing box of motor.

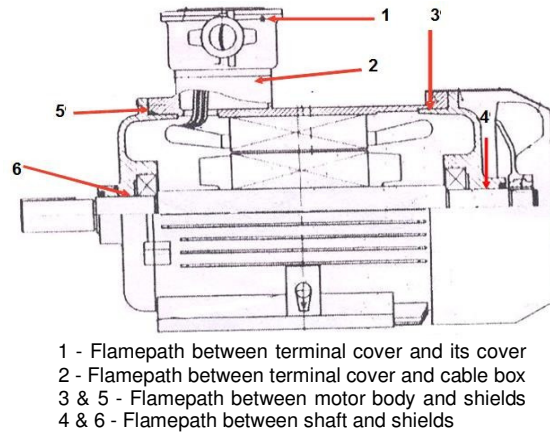

Figure 1. Flamepath locations in Exd motor

2.2 Light fixtureor

Flameproof lighting fittings like well glass, tube light luminaries, flood light; hand lamp may be used in the underground coal mines. The toughened glass is always supported with a backing plate or ring from inside of the fitting. The flamepaths & gaps or threaded flamepaths should always be measured and maintained between joints as specified in the test report/certificate. Low pressure sodium lamp should not be used because it is not allowed to use in the hazardous area. The following are the important points that require attention during the maintenance and installation:

1. Visual inspection for hair cracks on the body of light fitting and its glass.
2. The tightness of cover and number of bolts and its size.
3. Fastening should be done as per type of joint (like, spigot joint, flange joint, threaded joint) and number of thread engagement should be as per requirement of relevant standards.
4. Cemented path should be checked.
5. Attention should be given on wire guard, if light fitting is certified alongwith wire guard. During the maintenance if guard is not provided there may be risk of explosion due to change in impact energy of the toughened glass in the long run.
6. The temperature class should be maintained by replacing same size, rating and type of
7. Lamp.
8. Gasket should be replaced, if it is damaged, it can impair the weatherproofness as well as flameproofness of the light fixture as shown in Figure 2.
9. The gasket should not be provided in the product, if it is certified without gasket.
10. The nipple or bushing connected between two enclosures or common wall of enclosure to pass wires should not be removed and epoxy sealing should also be checked.



Figure 2. Improper fitting of Gasket in Exd apparatus

2.3 Flameproof JB/CP

Flameproof enclosures are assembled with different type of electrical and electronic components to make a system. The component may be flameproof and intrinsically safe or any other combination of protection. Flameproof control panel consists of more than one flameproof enclosure. Single flameproof enclosure is called junction box. The main purpose of a flameproof control panel is to regularize the power supply to motors, lighting fittings and various installations. The junction box is used to distribute the power supply from one terminal to another terminal. The control panel may have the different provision for different application like start/stop push button, glass window for voltmeter, ammeter etc. The operating rods passing through the bushes into cover should maintain cylindrical joint and diametrical clearance. All cable must be passed through certified and approved flameproof-cum-weatherproof appropriate cable gland. The proper fastening and tightening of high tensile strength (HTS) bolts should be checked after maintenance. Sometimes it is observed that enclosure is not fitted with all bolts as shown in Figure 3. If any bolt is missing, it should be replaced with identical size but in no case is left open. All bolts must be shrouded for gas group I [5]. Unused cable entry of panel/box must be closed by appropriate size and approved flameproof closing devices. Cables should not be passed without cable gland as shown in Figure 4. Normal/ordinary glass must not be replaced during repair. The drilling of any additional cable entry is not permitted in Exd CP/JB.



Figure 3. Missing of bolt in the Exd apparatus



Figure 4. Passing cable without Exd cable gland



2.4 Flameproof Plug and Socket

Generally, Exd plug and socket are used to make connection for medium and high voltage equipment in underground coal mines. Some important points are required to be ensured as given below:

1. It should be ensured that plug and sockets are interlocked mechanically or electrically. It is not permitted without locking.
2. The contacts of plug and socket should not be separated in energized condition.
3. The contacts should not be energized when plug and sockets are separated.
4. The flamepath between socket and entry of flameproof product while connected into cable entry through adopter plate should be checked.

2.5 Flameproof Cable Gland

Double compression flame proof cable glands are allowed to be used in underground coal mines in India as per DGMS (Directorate General of Mines and Safety) requirement and direct entry is also limited in some cases. Few important points are given for maintenance such as:

1. Sealing ring may be replaced identically as supplied by manufacturer, if it is damaged.
2. Proper cable should be inserted into suitable size of cable gland.
3. Number of thread engagement of nipple should be properly engaged into specific cable entry size, pitch and thread.
4. Certified and approved type of cable gland should be used in Ex equipment.

2.6 Flameproof Stopping /Closing Device

1. All unused cable entry must be plugged by Exd stopping devices.
2. It must be certified and approved for gas group I.
3. Thread engagement (flamepath) of stopping device into certified Exd equipment should be checked.

3. Maintenance of Intrinsically Safe Equipment

IS equipment are eminently suitable for telephone bell systems, data acquisition and transmission, automatic control and other specific applications. The faulty components of Ex i equipment may be replaced by an identical part like Coils, Resistors, ICs, Capacitor, Diode, Fuse, Zener diode supplied by the manufacture during the maintenance. Ex i equipment are generally operated by DC power supply and it should be ensured for positive and negative terminals before connecting the equipment. During live maintenance soldering is not allowed. Care should be taken in the associated apparatus (combination of IS and non-IS circuit) with those controlling the adjacent power source. If, for some reason, a safety component is damaged then special thought shall be given as to the cause of damage. Suppose a current limiting resistor (CLR) has failed by being burnt, then the cause of failure must be established. The reason of failure of CLR may be safety factor in most of the cases. It is advised that CLR should not be replaced if proper specification of CLR is not available. The creepage distance and clearance between connecting terminals should be checked. Care should be taken between the non-intrinsically safe and intrinsically safe terminals while connecting. The entity parameter should be checked before replacing the zener barrier or IS power supply.

The repair of printed circuit boards (PCBs) is sometimes considered but is usually impracticable. Removing components without damaging the board is difficult. It is also difficult to maintain the original creepage and clearance distances in the PCBs. The main advantages of intrinsic safety compared to flameproof enclosure regarding installation and maintenance that armoured cable is not needed, therefore reduced installation time. Test equipment should be checked to ensure that it is operational before connecting it to the apparatus in hazardous area and these test equipment are certified and approved for use in underground coal mines. The IS/IEC 60079-17 standard on inspection and maintenance permits the use of non-certified test equipment under 'gas clearance certificate' conditions issued by the end user.



The maintenance of intrinsically safe equipment should be entrusted only to competent persons who have already received instruction in the special techniques involved. The body material of instruments and tools required for maintenance purposes should be designed so that they will not make a hot spark when dropped. Insulation resistance, earth loop resistance and earth continuity resistance tests are required to be made during maintenance.

4. Discussion on Some Point for Maintenance of Ex Equipment

The following important points are required more commensurate care during inspection and or maintenance of Ex electrical equipment in hazardous area:

1. Any electrical apparatus should not be opened in energized condition in hazardous area.
 2. Rotating electrical machines should not be opened in the isolated running condition because voltage in the form of back emf may still exist.
 3. The permission should be taken by the competent authority for maintenance.
 4. Prior to taking the apparatus into operation in the said atmosphere, attention must be paid that any unused entry is plugged with certified flameproof plug.
 5. Cable conductors must not be subjected to any tensile stresses during use.
 6. The Ex equipment must not be tempered during its normal conditions of operations.
 7. Any kind of alternations or modifications is not allowed in the Ex equipment during its service/maintenance without the knowledge of testing authority.
 8. Any discrepancies or defects of electrical or mechanical nature observed in the equipment during their functioning must be brought to the notice of the manufacturer.
 9. A permanent instruction plate is to be prominently mounted near the apparatus by the manufacturer to draw user's attention to the need for regular and frequent inspection. It should be cleaned regularly.
 10. A scheme of regular inspection and maintenance of the items should be made.
 11. A proper record in bound-paged book/computerized data entry should always be maintained for every maintenance work conducted on the Ex equipment.
 12. To ensure that the equipment is dead before work commences and also they remain so effectively the power conductor shall be first discharged and then connected to earth.
 13. The equipment shall be, as far as possible kept free from accumulation of dust and dirt to protect excessive rise of temperature.
 14. Whenever flameproof equipment is being opened for maintenance, it should have specified gap after reassembly.
 15. History card/record for each equipment should be maintained keeping the full details of equipment.
 16. Ex expert should be present in the safety audit to enhance the safety.
 17. Only certified and approved appropriate Ex equipments for gas group I should be used [7].
 18. Bearing failures are the root cause for the majority of electric motor downtime, repair and replacement costs. It should be checked as per schedule. If any abnormal sound is noticed, action should be taken immediately.
 19. Lubricants should be applied regularly on the bearing of Ex motor.
 20. Flexible cable, flexible conduit, armoured cable and their termination should be inspected at regular intervals.
 21. It is required to check all the bolts, glands and stopper box.
 22. Proper earthing and tightening of electrical connections must be ensured.
 23. The motor fans and couplings should not rub.
 24. There should be no leakage of compound from stopper or cable boxes.
 25. The area of joint where flamepath is maintained should not be painted which can prevent breathing [8-9].
 26. Major repairing should only be under taken by the manufacturer or their authorized agent for Ex d motor.
-

27. Full number of thread should be engaged and it should not be left like as shown in Figure. 5. Even Ex d double compression cable glands should be provided with adequate size of cable with minimum required number of thread engagement. A check nut should be provided from the internal side to avoid unauthorised opening.
28. User must ensure that Ex d motor is certified and approved with variable speed drives and have valid approval for use in the underground coal mines.
29. Proper size allen-key should be used for opening hexagonal bolts.
30. Cell/battery used in the Ex apparatus must be replaced by identical one supplied by the manufacturer to ensure that cells/battery type and voltage is correct. The battery must be encapsulated with protection circuit for Ex i equipment.
31. The plain portion of the spigot joint should be fitted properly and it should not be left out without fixing as shown in Figure 6.



Figure 5. Improper thread engagement in Exd apparatus



Figure 6. Improper fitting of Spigot joint

5. Conclusions

It is anticipated that each inspection model needs to be tailored to the specific requirements of a given site and all the explosion protection equipment are to be considered for maintenance. Various important points on the safety management of Ex equipment are required to minimize the breakdown for increasing the production. Equipment operation, proper maintenance schedule and handling ability of Ex equipment in hazardous area is also vital. A safe, reliable, and convenient maintenance technique can enhance the safety of the underground coal mines. The points are very essential as discussed above for good practice in maintenance of Ex equipment for hazardous area of coal mines.